

GTi[™] Millennium

HVLP GRAVITY FEED

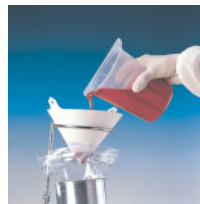

NEW!

DEVILBISS[®]

- **Advanced technology for the professional painter**
- **Precision engineered patented #2000 air cap** – Meets exacting performance demands, producing an extremely fine finish with all materials. Developed in conjunction with top American and European automotive paint companies to spray the latest materials
- **Large spray pattern** for fast coverage
- **Even distribution of metallics for no mottling or striping** – Excellent color matching capabilities
- **Optimum atomization for clearcoats and single stages** – Produces a high gloss finish and minimizes orange peel. Excellent fluid control for applying more film build with fewer passes
- **Lightweight and comfortable** – Classic JGA fit and feel, yet lighter weight Gun body styling changes for improved comfort
- **Extremely economical servicing** – Air cap, fluid tips and needle are fully interchangeable and available separately
- **Highly efficient HVLP design** – Complies with environmental regulation requiring high volume, low pressure. Saves material. Very little overspray
- **Low air pressure and volume requirements**
- **Easy to clean** – Plated gun body is gun washer safe and maintains its “like new” appearance. Smooth cup with wide opening
- **Stainless steel fluid tip and needle**
- **Less time spent on refills** – True 1-Liter aluminum cup with disposable push-on lid
- **Quick clean up and upside down spraying (no cup leaks)** – with E-Z Liner[™] disposable cup liners
- **GTi Millennium HVLP Spray Gun (170156/GTI-620G) includes:**
 1.3 mm, 1.4 mm, and 1.5 mm fluid tips
 1- Liter aluminum cup (120175/GFC-502) with push on lid
 Air adjusting valve with gauge (180006/HAV-501)
 Air cap cleaning kit, spray lube, fluid filter, gun hook
 (9) E-Z Liner[™] disposable cup liners (190966/OMX-70-K48)

GTi Millennium Gravity Feed

Order No. Model No.	Fluid Tip (mm)	Inlet Air Pressure	Applications
170156 GTI-620G	1.3 & 1.4	20-25 psi 25-30 psi	Base coats High solids clear coats and single stages
	1.5	20-25 psi 25-30 psi	Base coats Low solids clear coats, single stages

Specifications

30 psi inlet pressure delivers
 10 psi air cap pressure and
 15.5 cfm air volume

192137 (GTI-5033-2000) Air Cap Test Kit (Order separately)
 Provides consistent setup and regulatory proof of air cap pressure.

GTi™ Millennium HVLP Gravity Feed Spray Gun

170156 (GTI-620G) HVLP Gravity Feed

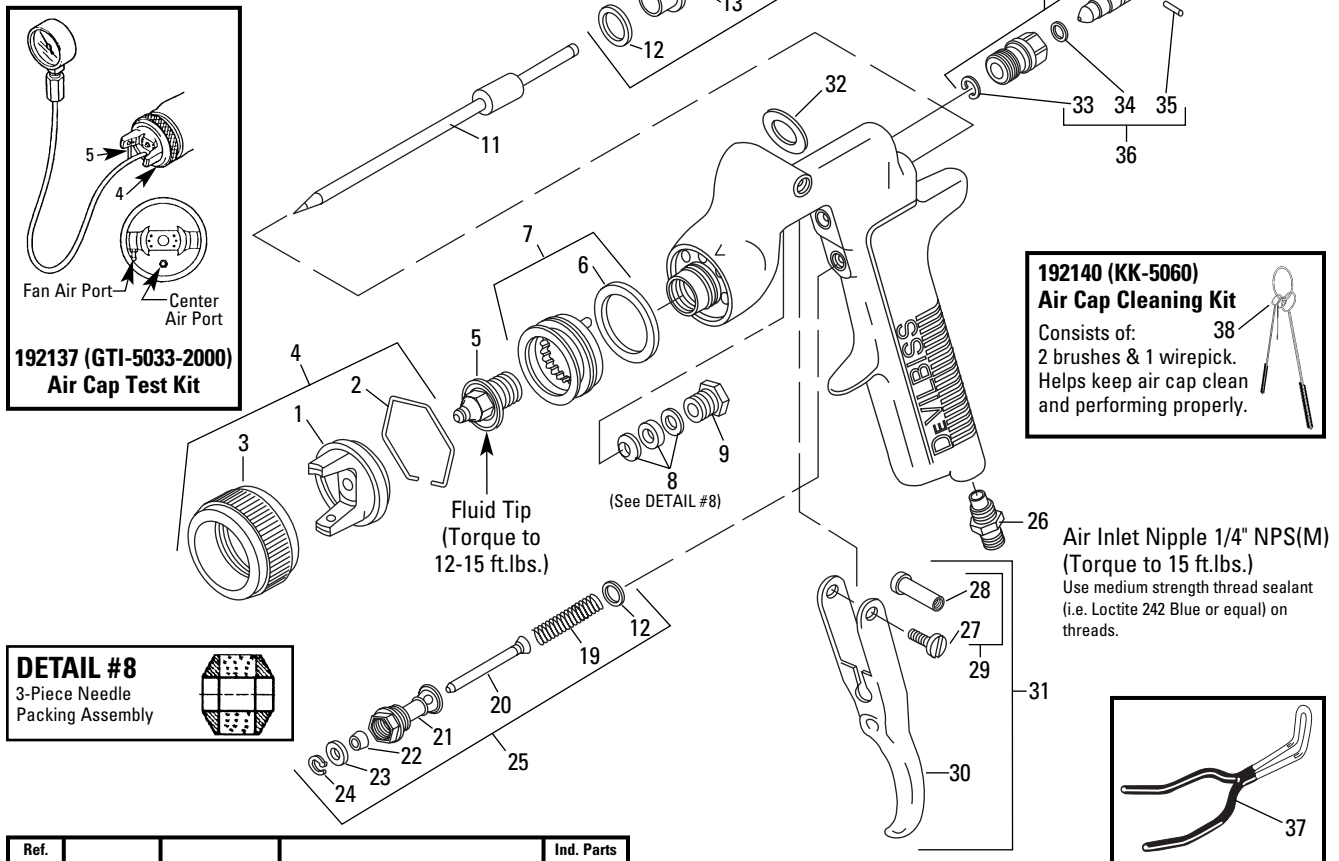

192140 (KK-5060) Air Cap Cleaning Kit
Consists of:
2 brushes & 1 wirepick.
Helps keep air cap clean and performing properly.

192140 (KK-5060) Air Cap Cleaning Kit
Consists of:
2 brushes & 1 wirepick.
Helps keep air cap clean and performing properly.

NOTE: Gun Repair Kit 192227 (KK-5058-2) Contains:

Ref. No.	Description	Qty.
6	Baffle Seal	1
8	Packing	1
12	Gasket Kit	2
14	Fluid Needle Spring	1
15	Spring Pad	1
19	Air Valve Spring	1
20	Air Valve	1
22	U Cup Seal	1
23	Washer	1
24	Snap Ring	1
32	Fluid Cup Gasket	1
33	Retaining Clip	1
34	Seal	1
35	Pin	1

DETAIL #8
3-Piece Needle Packing Assembly

Ref. No.	Order No.	Model No.	Description	Ind. Parts Required
1	—	—	Air Cap	1
2	191972	JGA-156-K10	Spring Clip (Kit of 10)	1
3	192042	GTI-3	Air Cap Retaining Ring	1
4	192136	GTI-407-2000	Air Cap (#2000) and Retaining Ring	1
5	See Chart 1	See Chart 1	Fluid Tip	1
*6	192179	GTI-33-K5	Baffle Seal (Kit of 5)	1
7	192178	GTI-425	Baffle Assembly	1
*8	192109	JGA-4035-K5	Packing (Kit of 5)	1
9	190893	34411-122-K10	Packing Nut	1
10	192050	GTI-404	Spreader Valve	1
11	192054	GTI-413	Fluid Needle	1
*12	190161	JGS-72-K10	Gasket Kit (Teflon) (Kit of 10)	2
13	—	—	Body Bushing	1
*14	—	—	Fluid Needle Spring	1
*15	—	—	Spring Pad	1
16	190894	MBD-19-K10	Spring and Pad (Kit of 10)	1
17	192043	GTI-414	Needle Adjusting Screw	1
18	192139	KK-5059	Bushing, Spring, Pad and Knob Kit	1
*19	—	—	Air Valve Spring	1
*20	—	—	Air Valve	1
21	—	—	Air Valve Body	1
*22	—	—	U Cup Seal	1
*23	—	—	Washer	1
*24	—	—	Snap Ring	1
25	190780	JGS-449-1	Air Valve Assembly	1
26	190281	P-MB-51	Air Inlet Nipple 1/4" NPS(M)	1
27	—	—	Trigger Stud Screw	1
28	—	—	Trigger Stud	1
29	190889	JGS-478	Stud and Screw Kit	1
30	—	—	Trigger	1
31	191943	JGS-477-1	Trigger Stud, Screw Kit	1
*32	192151	KGP-13-K5	Cup Gasket (Kit of 5)	1
*33	—	—	Retaining Clip	1
*34	—	—	Seal	1
*35	—	—	Pin	1
36	192229	GTI-428-K5	Clip, Seal & Pin Kit (5 Each)	1
37	192219	—	Gun Holder, Coated	1
38	192140	KK-5060	Air Cap Cleaning Kit	1

Chart 1

Fluid Tip Order No.	Fluid Tip Model No.	Tip Size I.D. in.	Tip Size I.D. mm
192124	GTI-213-12	.047	1.2
192134	GTI-213-13	.051	1.3
192044	GTI-213-14	.055	1.4
192135	GTI-213-15	.059	1.5
192045	GTI-213-16	.063	1.6
192046	GTI-213-18	.070	1.8
192047	GTI-213-20	.079	2.0
192132	GTI-213-22	.086	2.2

Setup Information by Paint Brand:
Request DeVilbiss paint company recommendation chart or consult your paint supplier specifications for the material being sprayed.

NOTE: See Section G-1 for GFC-502 Cup parts breakdown.

* A quantity of necessary parts is included in 192227 Repair Kit (KK-5058-2) for complete gun repair and should be kept on hand for service convenience.

Suffixes: -K5 designates kit of multiple parts. Example: JGA-4035-K5 is a kit of 5 packings.



ITW Automotive Refinishing
An Illinois Tool Works Company
1724 Indian Wood Circle, Suite J-K
Maumee, OH 43537-4048
Telephone 419-891-8100
Fax 419-891-8110
www.devilbiss.com

